



measuring converter **AD4RS**

4 inputs for standardized signal measuring

0 - 10 V, 0 - 20 mA, 4 - 20 mA

Communication via RS232 or RS485 lines



AD4RS

Datasheet

Created: 4.5.2007

Last update: 9/17/2021 3:18 PM

Number of pages: 16

© 2021 Papouch s.r.o.

Papouch s.r.o.

Address:

**Strasnicka 3164
102 00 Prague 10
Czech Republic**

Tel:

+420 267 314 267

Internet:

en.papouch.com

E-mail:

info@papouch.com



CONTENT

About device	4
Application	4
Features	4
Block diagram and operation	5
Examples of connection structure	5
Voltage measurement.....	5
Sensors with output of 0 to 20 mA and own power supply	6
Sensors with output of 0 to 20 mA, supplied through current loop.....	6
Connectors	7
Measuring terminals.....	7
Power supply	7
RS232.....	8
RS485.....	9
Indications.....	10
Detailed description of communication protocol	10
Configuration software	10
Technical parameters	11
Available Designs	12

ABOUT DEVICE

AD4RS measuring converter is a 4-input A/D converter which enables the user to measure to four current inputs ranging from 0(4) to 20 mA or voltage between 0 and 10 V.¹ The measured values are then transferred to a superior system in digital form.

AD4 has been produced in three versions differing in their communication interface – the data can be transferred via RS232/RS485 lines, over USB interface or the Ethernet. **The AD4RS version communicates via RS232 serial line or RS485 bus.**



Application

- Measurement of values from sensors with voltage or current output.
- Reading of sensors whose output is a standardised current signal
- Digitalisation of measured values from level, pressure, temperature, distance and other sensors

Features

- Four analogue inputs for current or voltage
- Measuring scale divided into 10 000 divisions
- Full isolation of the measuring part from power supply and communication lines
- Measurements carried out by a multiplex 16 bit sigma-delta A/D converter
- The maximum measuring speed of each input equals 500 ms
- Two measuring modes:
 - Single measurement – sends one measured value from each input upon a request.
 - Continuous measuring – measures all inputs in the set interval and regularly sends the measured values via the communication line.
- Communication via **RS232** (COM port) or **RS485** (industrial bus)
- Communication protocol **Spinel** or **MODBUS RTU** (user switchable)

¹ The basic range (typically 10 V) can be changed to range from 2.5 to 100 V (including bipolar) or to a current range from 0 to 20 mA, 4 to 20 mA or other as per your requirement. If you need a range for your application that is not listed here, write it in the order notes or contact us.

- Modbus RTU makes the converter easy to integrate into your system or connect to a PLC
- The Wix software for Windows can display measured values, save them to disk, etc.
- Wide range of power supply voltage (8 to 30 V)

BLOCK DIAGRAM AND OPERATION

The measuring part is fully isolated from the communication line and power supply.

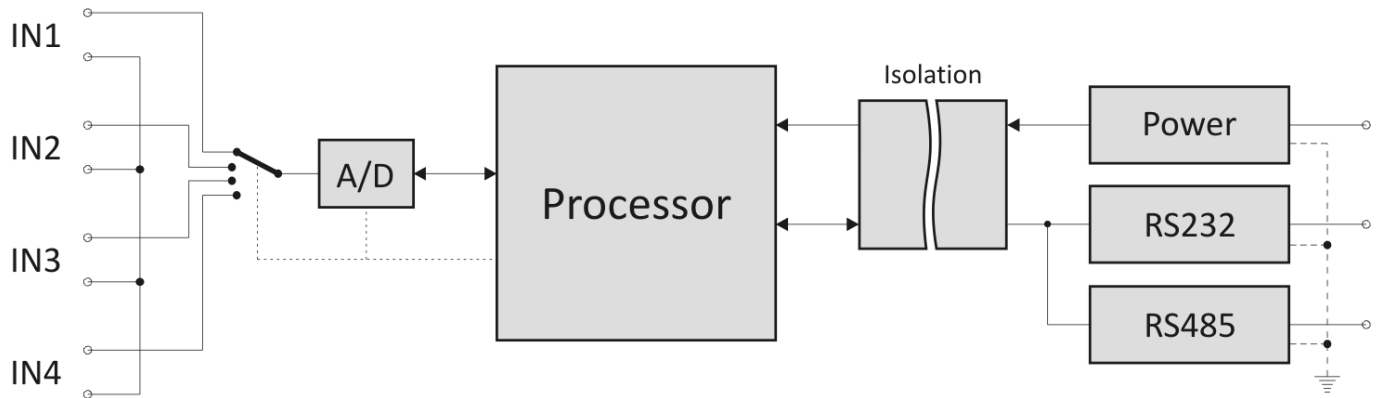

Fig. 1 – Block diagram of AD4RS

The AD4RS measuring device uses one switched sigma-delta A/D converter. After switching on the power supply voltage, the processor initiates the A/D converter and set the device parameters according to the data saved in memory. Then the device start to regularly measure the values of voltage found on analog inputs and saves the results into the integrated memory.

In the continuous measuring mode AD4RS sends the measured values in the set interval.

EXAMPLES OF CONNECTION STRUCTURE

The following figures show examples of AD4RS connection structure.

Voltage measurement

An example of voltage supply connection to AD4RS terminals. The inputs are fully isolated from the power supply.

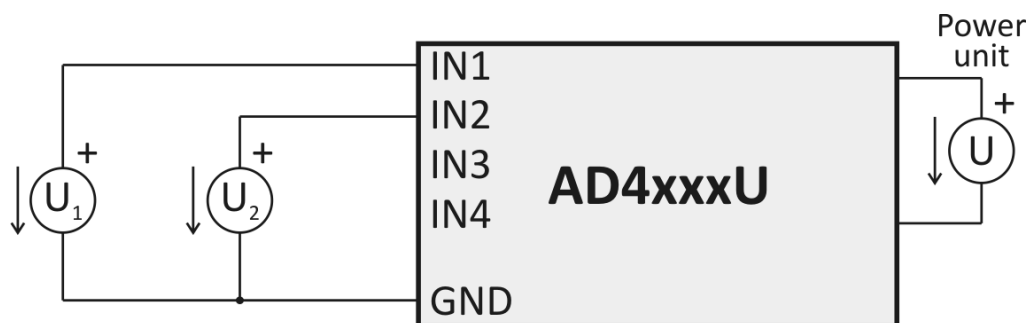

Fig. 2 – Voltage measurement

Sensors with output of 0 to 20 mA and own power supply

Sensors with currents outputs can be connected directly to the inputs with current range and supplied either from their own power supply (in this case, the sensor is isolated from AD4RS power supply) or from the same supply as AD4RS (see the dashed lines in Fig. 3; in this case, sensors are not isolated).

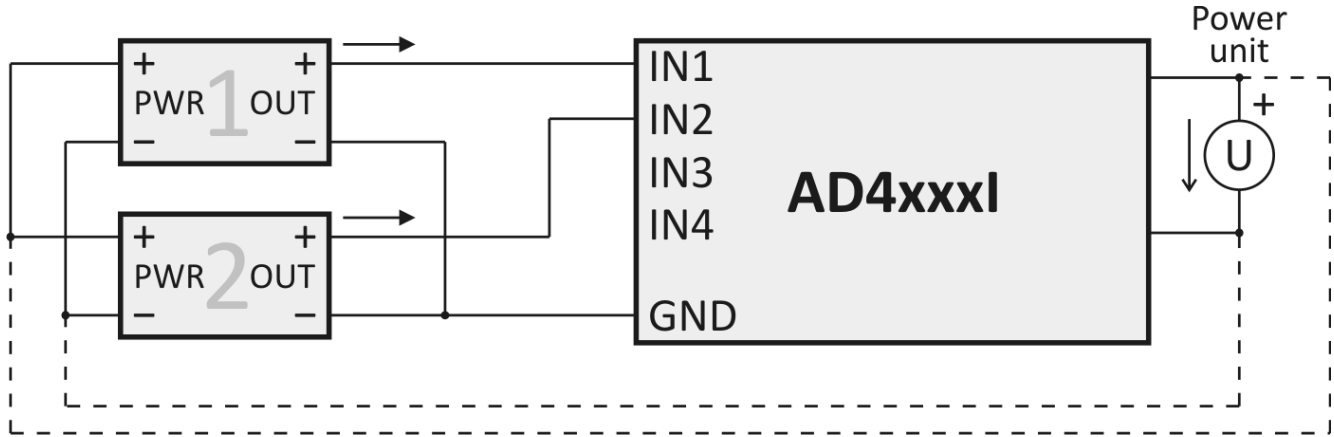

Fig. 3 – Current sensors with their own power supply

Sensors with output of 0 to 20 mA, supplied through current loop

With a separate source for sensors

In this case, the sensors are isolated from AD4RS power supply.

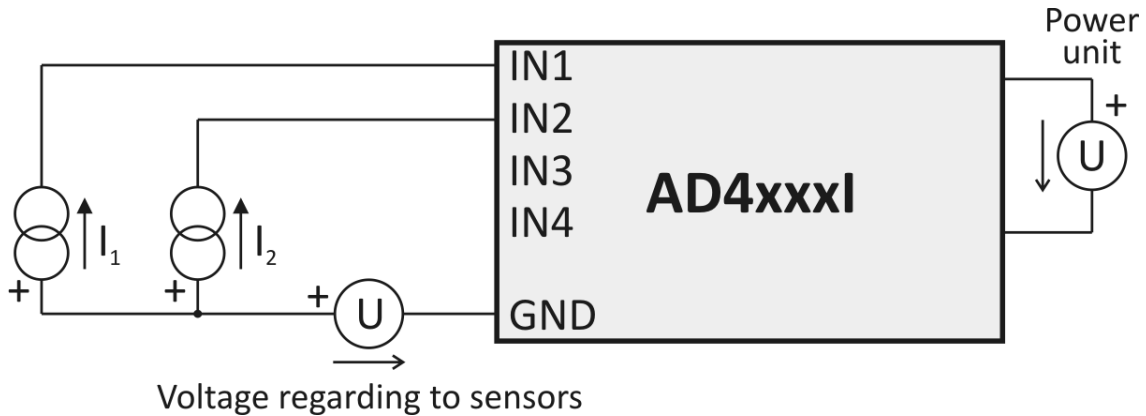

Fig. 4 – Current sensors with separate supply through current loop

With a joint source for sensors and AD4RS

In this case, the sensors are isolated with AD4RS power supply.

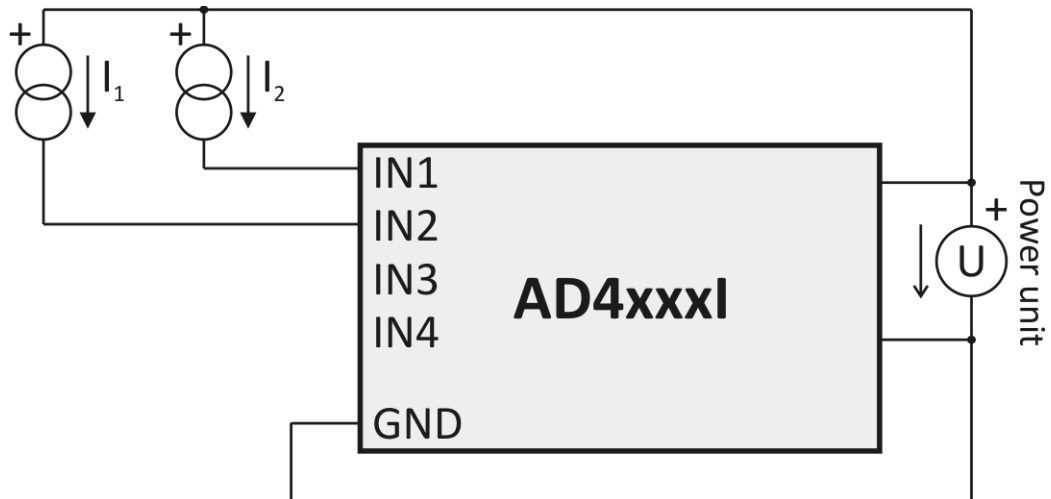

Fig. 5 – Current sensors supplied through current loop from joint source with AD4RS

CONNECTORS

Measuring terminals

Note: The input types (voltage or current) are unchangeable and must be specified by the user when ordering the device. Subsequently they can be changed only by the manufacturer.

The measuring terminal unit is a six-slot terminal unit shown in Figure 6. It contains four inputs and two grounding terminals.

All four measuring terminals have a joint grounding on the two sides of the terminal unit. This grounding is isolated from other grounding terminals found in the device.

The measuring terminals have been designed for the measurement of voltage or current. Wires can be connected individually and fixed by means of a screw (use flat bladed screwdriver 2.5 mm).

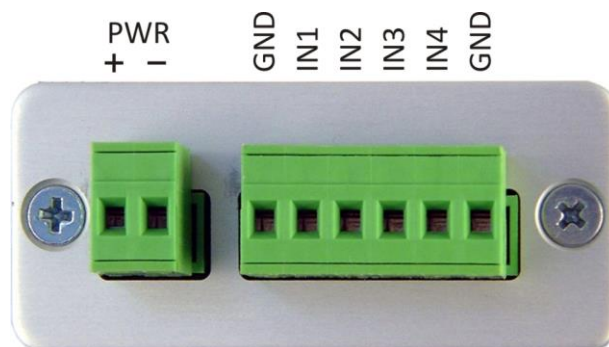

Fig. 6 – Terminals for power supply connection and measuring terminals

Power supply

DC supply **8 to 30 V** shall be connected to the double terminal shown in Fig. 6. The input has an integrated polarity reversal protection.

Wires can be connected individually and fixed by means of a screw (use flat bladed screwdriver 2.5 mm).

RS232

RS232 serial line shall be connected via the D-SUB9F connector (female plug). A usual extension cable is suitable for RS232 connection. The serial line connector is shown in Fig. 7, the connection diagram for individual conductors can be found in Fig. 8.

A simultaneous use of RS232 and RS485 as communication interfaces is possible. AD4RS is able of receive commands only from one line at a time. It is necessary to make sure AD4RS does not receive commands from both RS232 and RS485 simultaneously.

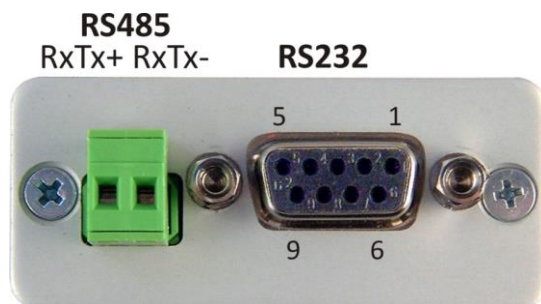

Fig. 7 – Terminals for RS232 and RS485² serial lines connection

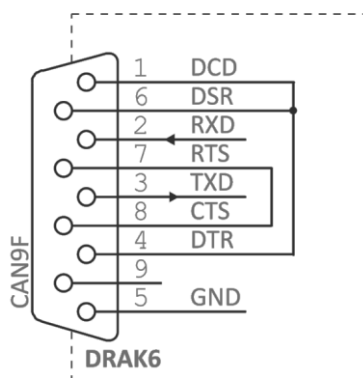

Fig. 8 – RS232 connector diagram

² RS485 line conductors are often marked as A (RxTx+) and B (RxTx-).

RS485

The connection to RS485 bus can be made by means of the terminal next to D-SUB9 connector. The terminal connection is shown in Fig. 7.

A simultaneous use of RS485 and RS232as communication interfaces is possible. AD4RS is able of receive commands only from one line at a time. It is necessary to make sure AD4RS does not receive commands from both RS485 and RS232 simultaneously.

Connection of RS485 termination

It is not necessary to use the termination in most cases. However, if the RS485 communication line runs through interfering environment (it runs in parallel with power conductors etc.) it is suitable to connect the termination. There can be only up to 2 modules with connected termination on one line (at the opposite ends of the line).

Inside the device can be found a jumper which can be shorted out to connect the termination (see Fig. 9). The housing can be opened after unscrewing the screws on the sides.

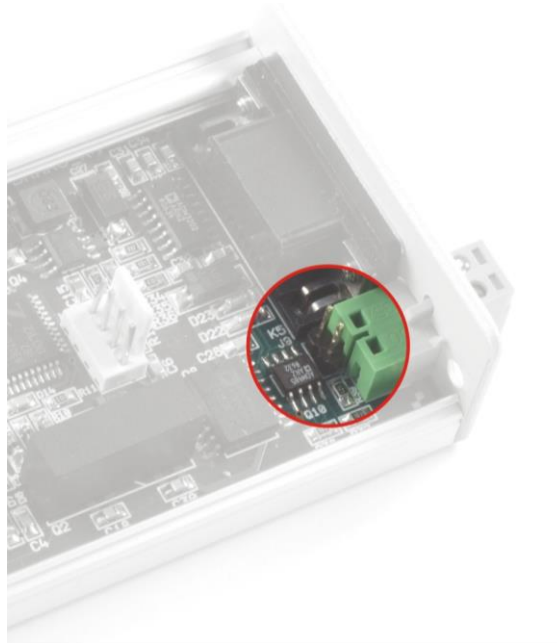

Fig. 9 – Jumper for RS485 termination

INDICATIONS

The device contains three light indicators showing the operational status:

ON

Green light. Lights when the supply voltage is connected.

COM

Yellow light. Flashes once after the device initiation following the power supply switch-on and also during communication running on RS232 or RS485.

OVR

Red light. Flashes repeatedly when the input range of any channel has been exceeded.

Warning: When the channel is switched to “4 to 20 mA” range, AD4 indicates not only exceeding the upper limit, but also value dropping below the lower limit if the current is lower than 4 mA. It means that the drop is indicated also when no sensor is connected (because the current is zero).

DETAILED DESCRIPTION OF COMMUNICATION PROTOCOL

Complete descriptions of the Spinel and Modbus RTU communication protocols that AD4RS uses are available for download on the [AD4RS website at papouch.com](http://www.papouch.com).

CONFIGURATION SOFTWARE

To configure and preview the values, the *AD4 Configurator* software can be downloaded from the [AD4RS website at papouch.com](http://www.papouch.com).



fig. 10 - configuration software for AD4 converters

TECHNICAL PARAMETERS

Analog inputs:

Number of inputs	4
Input type.....	unipolar
Voltage input range	0 – 10 V ¹ ; 10 000 divisions
Maximum allowed input voltage.....	-5 to +30 V
Input impedance (voltage inputs).....	1 MΩ (100 kΩ / 1 V)
Current input ranges	0 – 20 mA ¹ ; 4 – 20 mA ¹ ; 10 000 divisions
Calibration	10 000 divisions/range
A/D converter resolution	16 bits
Maximum non-linearity.....	10 divisions
Maximum zero error	10 divisions
Maximum rang error	10 divisions
Maximum measuring speed.....	500 ms (all channels)
Calibration method	software ³

Control interface:

Type.....	RS232 and RS485
Connector	slip-on terminal unit
Communication speed	adjustable 1200 Bd to 115.2 kBd (default: 9.6 kBd) ⁴
Number of data bits	8
Parity	no parity
Number of stop-bits	1
Isolation	± 300 V
Communication protocol	Modbus RTU or Spinel
Default protocol	Spinel
Minimum response delay.....	2 ms ⁵

Power supply:

Supply voltage	DC 8 to 30 V (with polarity reversal protection)
Power consumption	usually 30 mA at 12 V

Other parameters:

Operation temperature.....	-20 °C to +70 °C
----------------------------	------------------

³ Calibration is described in greater detail in the communication protocol description which is available to be downloaded from the device web page.

⁴ Lower or higher communication speeds can be added on request.

⁵ Due to the delay when switching the communication direction over to RS485.

Dimensions	104 × 55 × 24 mm
Dimensions incl. connectors	121 × 55 × 24 mm
Dimensions incl. DIN rail holder	104 × 55 × 33 mm
IP Code	IP 30
Weight.....	145 g

Available Designs

Assembly:

- Without a holder (*standard design*)
- With a DIN rail holder



Fig. 11 - AD4RS with DIN rail holder

- With a wall holder



Fig. 12 – AD4 with wall holder

Input ranges:

- 0 to 10 V
- 0 to 20 mA
- 4 to 20 mA
- It is possible to deliver another current or voltage range upon request; it is also possible to combine more ranges in one device

Please do not hesitate to contact us if you have further specific requirements for the design and functionality of the AD4RS module.

Papouch s.r.o.

Data transmission in industry, line and protocol conversions, RS232/485/422/USB/Ethernet/GPRS/WiFi, measurement modules, intelligent temperature sensors, I/O modules, and custom-made electronic applications.

Address:

**Strasnicka 3164
102 00 Prague 10
Czech Republic**

Tel:

+420 267 314 267

Internet:

www.papouch.com

E-mail:

info@papouch.com

